

DISC GRINDER

To certify on the disc grinder you will need to know:

1. The safety rules.
2. The parts of the disc grinder.
3. How to grind steel with the disc grinder.

Disc grinder safety rules

1. Wear eye protection. (safety glasses & face shield)
2. Wear gloves and eliminate loose clothing.
3. Disconnect from power source when changing disc or making adjustments.
4. Use properly adjusted guard at all times.
5. Clamp small pieces so grinder will not throw your work.
6. Discard excessively worn or cracked grinding disc.
7. Start disc above work then lower to metal surface. Stop disc above the surface you are grinding.
8. Wait till grinder has stopped before setting on bench top.
9. Warn others in area prior to grinding.

Disc grinder parts

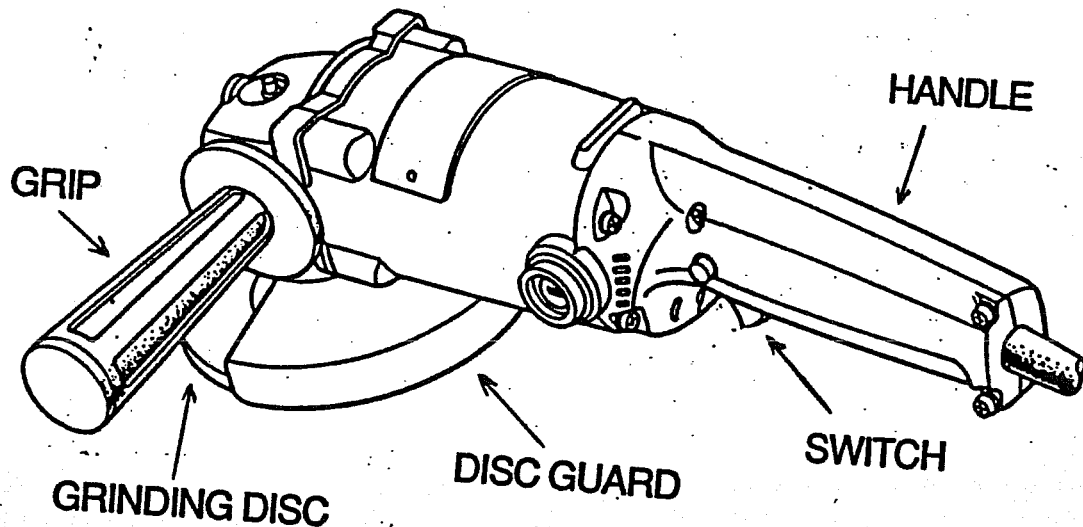

How to grind with the disc grinder

1. Clamp material in vise.
2. Make sure the cord is behind you and away from the grinding disc.
3. Start grinder above your metal, then lower disc to the metal. Hold your disc at a slight angle to the metal. Move disc back and forth across the surface.
4. Watch to make sure sparks are not flying across the shop or hitting someone in the area.
5. When you have finished grinding, lift disc from the metal and wait for the disc to stop before setting grinder down.